

Lenco

FM PORTABLE RADIO MPR-35BK

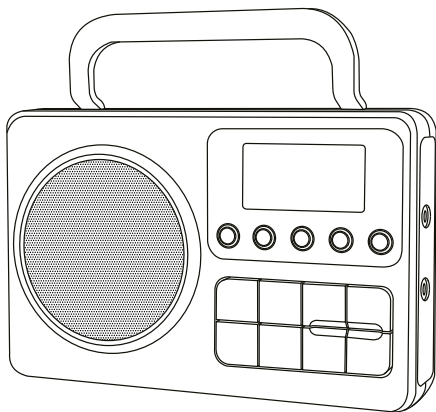

INSTRUCTION MANUAL

For information and support, www.lenco.com

CAUTION

Usage of controls or adjustments or performance of procedures other than those specified herein may result in hazardous radiation exposure.

PRECAUTIONS BEFORE USE

KEEP THESE INSTRUCTIONS IN MIND:

1. Do not cover or block any ventilation openings. When placing the device on a shelf, leave 5 cm (2") free space around the whole device.
2. Install in accordance with the supplied user manual.
3. Keep the device away from heat sources such as radiators, heaters, stoves, candles and other heat-generating products or naked flame. The device can only be used in moderate climates. Extremely cold or warm environments should be avoided. Working temperature between 0° and 35°C.
4. Avoid using the device near strong magnetic fields.
5. Electrostatic discharge can disturb normal usage of this device. If so, simply reset and restart the device following the instruction manual. During file transmission, please handle with care and operate in a static-free environment.
6. Warning! Never insert an object into the product through the vents or openings. High voltage flows through the product and inserting an object can cause electric shock and/or short circuit internal parts. For the same reason, do not spill water or liquid on the product.
7. Do not use in wet or moist areas such as bathrooms, steamy kitchens or near swimming pools.
8. The device shall not be exposed to dripping or splashing and make sure that no objects filled with liquids, such as vases, are placed on or near the apparatus.
9. Do not use this device when condensation may occur. When the unit is used in a warm wet room with damp, water droplets or condensation may occur inside the unit and the unit may not function properly; let the unit stand in power OFF for 1 or 2 hours before turning on the power: the unit should be dry before getting any power.
10. Although this device is manufactured with the utmost care and checked several times before leaving the factory, it is still possible that problems may occur, as with all electrical appliances. If you notice smoke, an excessive build-up of heat or any other unexpected phenomena, you should disconnect the plug from the main power socket immediately.
11. This device must operate on a power source as specified on the specification label. If you are not sure of the type of power supply used in your home, consult your dealer or local power company.
12. Keep away from animals. Some animals enjoy biting on power cords.
13. To clean the device, use a soft dry cloth. Do not use solvents or petrol based fluids. To remove severe stains, you may use a damp cloth with dilute detergent.
14. The supplier is not responsible for damage or lost data caused by malfunction, misuse, modification of the device or battery replacement.
15. Do not interrupt the connection when the device is formatting or transferring files. Otherwise, data may be corrupted or lost.
16. If the unit has USB playback function, the USB memory stick should be plugged into the unit directly. Don't use an USB extension cable because it can cause interference resulting in failing of data.
17. The rating label has been marked on the bottom or back panel of the device.
18. This device is not intended for use by people (including children) with physical, sensory or mental disabilities, or a lack of experience and knowledge, unless they're under supervision or have received instructions about the correct use of the device by the person who is responsible for their safety.
19. This product is intended for non professional use only and not for commercial or industrial use.
20. Make sure the unit is adjusted to a stable position. Damage caused by using this product in an unstable position vibrations or shocks or by failure to follow any other warning or precaution contained within this user manual will not be covered by warranty.
21. Never remove the casing of this device.
22. Never place this device on other electrical equipment.
23. Do not allow children access to plastic bags.
24. Only use attachments/accessories specified by the manufacturer.
25. Refer all servicing to qualified service personnel. Servicing is required when the device has been damaged in any way, such as the power supply cord or the plug, when liquid has been spilled or objects have fallen into the device, when the device has been exposed to rain or moisture, does not operate normally, or has been dropped.
26. Long exposure to loud sounds from personal music players may lead to temporary or permanent hearing loss
27. If the product is delivered with power cable or AC power adaptor:
 - If any trouble occur, disconnect the AC power cord and refer servicing to qualified personnel.
 - Don't step on or pinch the power adaptor. Be very careful, particularly near the plugs and the cable's exit point. Do not place heavy items on the power adaptor, which may damage it. Keep the entire device out of children's reach! When playing with the power cable, they can seriously injure themselves.
 - Unplug this device during lightning storms or when unused for a long period.
 - The socket outlet must be installed near the equipment and must be easily accessible.
 - Do not overload ac outlets or extension cords. Overloading can cause fire or electric shock.
 - Devices with class 1 construction should be connected to a main socket outlet with a protective earthed connection.
 - Devices with class 2 construction do not require a earthed connection.
 - Always hold the plug when pulling it out of the main supply socket. Do not pull the power cord. This can cause a short circuit. Do not use a damaged power cord or plug or a loose outlet. Doing so may result in fire or electric shock.

28.If the product contains or is delivered with a remote control containing coin/cell batteries:

Warning: "Do not ingest battery, Chemical Burn Hazard" or equivalent working.

[The remote control supplied with] This product contains a coin/button cell battery. If the battery is swallowed, it can cause severe internal burns in just 2 hours and can lead to death.

Keep new and used batteries away from children.

If the battery compartment does not close securely, stop using the product and keep it away from children.

If you think batteries might have been swallowed or placed inside any part of the body, seek immediate medical attention.

29.Caution about the use of Batteries:

Danger of explosion if battery is incorrectly replaced. Replace only with the same or equivalent type.

Battery cannot be subjected to high or low extreme temperatures, low air pressure at high altitude during use, storage or transportation.

Replacement of a battery with an incorrect type that can result in an explosion or the leakage of flammable liquid or gas.

Disposal of a battery into fire or a hot oven, or mechanically crushing or cutting of a battery, that can result in an explosion.

Leaving a battery in an extremely high temperature surrounding environment that can result in an explosion or that leakage of flammable liquid or gas.

A battery subjected to extremely low air pressure that may result in an explosion or the leakage of flammable liquid or gas.

Attention should be drawn to the environmental aspects of battery disposal.

INSTALLATION

Unpack all parts and remove protective material.

Do not connect the unit to the mains before checking the mains voltage and before all other connections have been made.

LOCATION OF CONTROLS

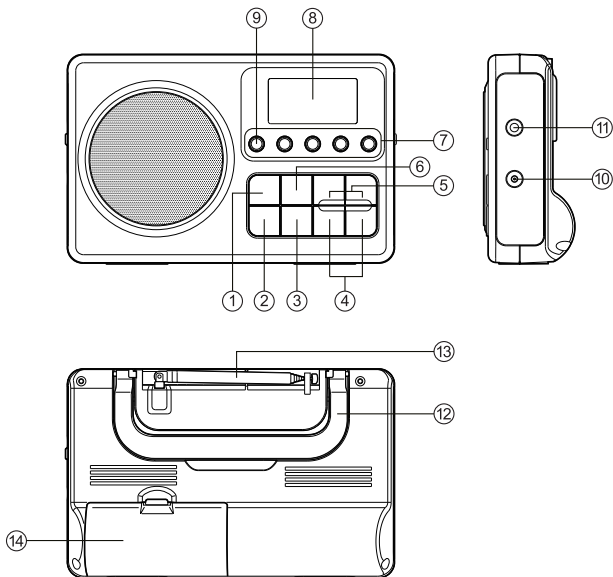

1. **MEMORY:** Press to save radio stations to a preset.
2. **POWER:** Press to power the radio on.
3. **SCAN:** Press to make a full scan.
4. **TUNE+ -:** Press to change station. Press and hold to auto scan to the next available station.
5. **VOLUME+ -:** Press to set volume level
6. **PRESET:** Press to open preset selections.
7. **PRESET NUMBERS:** Press to select which preset you want to tune to.
8. **LCD DISPLAY**
9. **LOCK:** Press and hold to lock controls on radio. Press and hold again to unlock controls on radio.
10. **AC POWER INPUT**
11. **HEADPHONES JACK**
12. **CARRYING HANDLE**
13. **TELESCOPIC ANTENNA**
14. **BATTERY COMPARTMENT**

Using the Power Adapter (included)

1. Plug the power adapter (included) into the AC power input on the side of your radio.
2. Plug the other end of the power cord into an outlet.

WARNING:
WHILE THE RADIO IS USING BATTERY POWER,
TAKE ALL THE BATTERIES OUT BEFORE USING
THE POWER ADAPTER

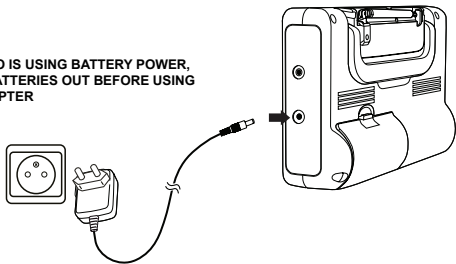

Using Battery Power

Requires 3 size D batteries (not included).

1. Pull the battery compartment tab down and lift up to open battery cover.
2. Insert 3 size D batteries (not included) into the battery compartment. Make sure the batteries are correctly aligned, as shown in the figure..

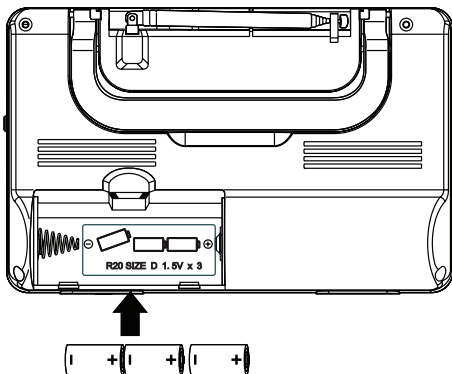

Turning Your Radio On and Off

Press the POWER button on the front of the radio to Power the radio on.

Press the POWER button again to power the radio off .

Finding a Radio Station

Note: To improve reception it is recommended to fully extend the antenna on the back of the radio.

1. With the radio on, perform a full scan by pressing the SCAN button.
2. Press and hold the TUNE buttons to start automatically scanning radio station frequencies.

Once a radio station is found, it will stop the scan.

Using the Memory Function (Auto)

You can save up to 20 FM stations as presets for easy access to your favorite radio stations.

1. Press and hold the SCAN button to scan and store all available stations.
2. Press PRESET NUMBER buttons (1-5) for the first five saved stations.
3. Press the PRESET button. Then press the TUNE buttons to search through saved stations (6-20).

Using the Memory Function (Manual)

1. Press the TUNE buttons to select the frequency you want.
2. Press the MEMORY button.
3. Press the TUNE buttons to select which preset number you want to save the station to (1-20).
4. Press the MEMORY button to save.
5. Press the PRESET button. Press the TUNE buttons to search through saved stations (1-20) or press PRESET NUMBER buttons to quickly select stations saved from (1-5).

Using Headphones

Using a 3.5mm audio cable, insert the 3.5mm plug into the headphone jack on the radio (Headphones not included).

Important: To avoid hearing damage, set the volume to the lowest level before placing your Headphones on your ears. Be careful when listening at high volume for prolonged periods of time, as it can damage your hearing.

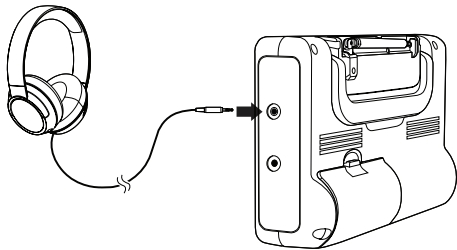

Power Adapter

Information	Value and and precision
Manufacturers name or trade mark, commercial registration and address	DongGuan Obelieve Electronic Co.,Ltd
Model Identifier	OBL-0590500E
Input voltage	AC 100-240V
Input AC frequency	50/60Hz
Output voltage	DC 5.9V
Output current	0.5A
Output Power	3W
Average active efficiency	74.29%
Efficiency at low load	0.08W
No load Power consumption(10%)	74.29%

SPECIFICATIONS

Radio

Frequency range:

FM: 87.5 - 108MHz

Antenna:

Telescopic

General

Input voltage:

DC 5.9V

Power consumption:

3 W

Output power:

0.5 W (RMS)

Speaker size:

3.5 "

Speaker impedance:

8 Ohm

Phones output:

3.5mm Jack

Battery specification:

3 x 1.5V R20/D SIZE

Dimensions:

212 x 59 x 135mm (wxdxh)

Weight of unit:

0.42 Kg

Weight of adapter:

0.06 Kg

Commaxx International reserves the right to change the contents of this document without notice.

Guarantee

Lenco offers service and warranty in accordance with the European law, which means that in case of repairs (both during and after the warranty period) you should contact your local dealer.

Important note: It is not possible to send products that need repairs to Lenco directly.

Important note: If this unit is opened or accessed by a non-official service center in any way, the warranty expires.

This device is not suitable for professional use. In case of professional use, all warranty obligations of the manufacturer will be voided.

Disclaimer

Updates to Firmware and/or hardware components are made regularly. Therefore some of the instruction, specifications and pictures in this documentation may differ slightly from your particular situation. All items described in this guide for illustration purposes only and may not apply to particular situation. No legal right or entitlements may be obtained from the description made in this manual.

Disposal of the Old Device



This symbol indicates that the relevant electrical product or battery should not be disposed of as general household waste in Europe. To ensure the correct waste treatment of the product and battery, please dispose them in accordance to any applicable local laws of requirement for disposal of electrical equipment or batteries. In so doing, you will help to conserve natural resources and improve standards of environmental protection in treatment and disposal of electrical waste (Waste Electrical and Electronic Equipment Directive).

DECLARATION OF CONFORMITY

Hereby, Commaxx declares that the radio equipment type [Lenco MPR-035] is in compliance with directive 2014/53/EU. The full text of the EU declaration of conformity is available at the following internet address:
https://commaxx-certificates.com/doc/mpr-035_doc.pdf

Type RF	Frequency range (MHz)	Power (dBm)
FM	87.5 -108	—



WARNING:

To prevent possible hearing damage, do not listen at high volume levels for long periods.

Service

For more information and helpdesk support, please visit www.lenco.com
Commaxx B.V. Wiebachstraat 37, 6466 NG Kerkrade, The Netherlands.